

# Projector Concept

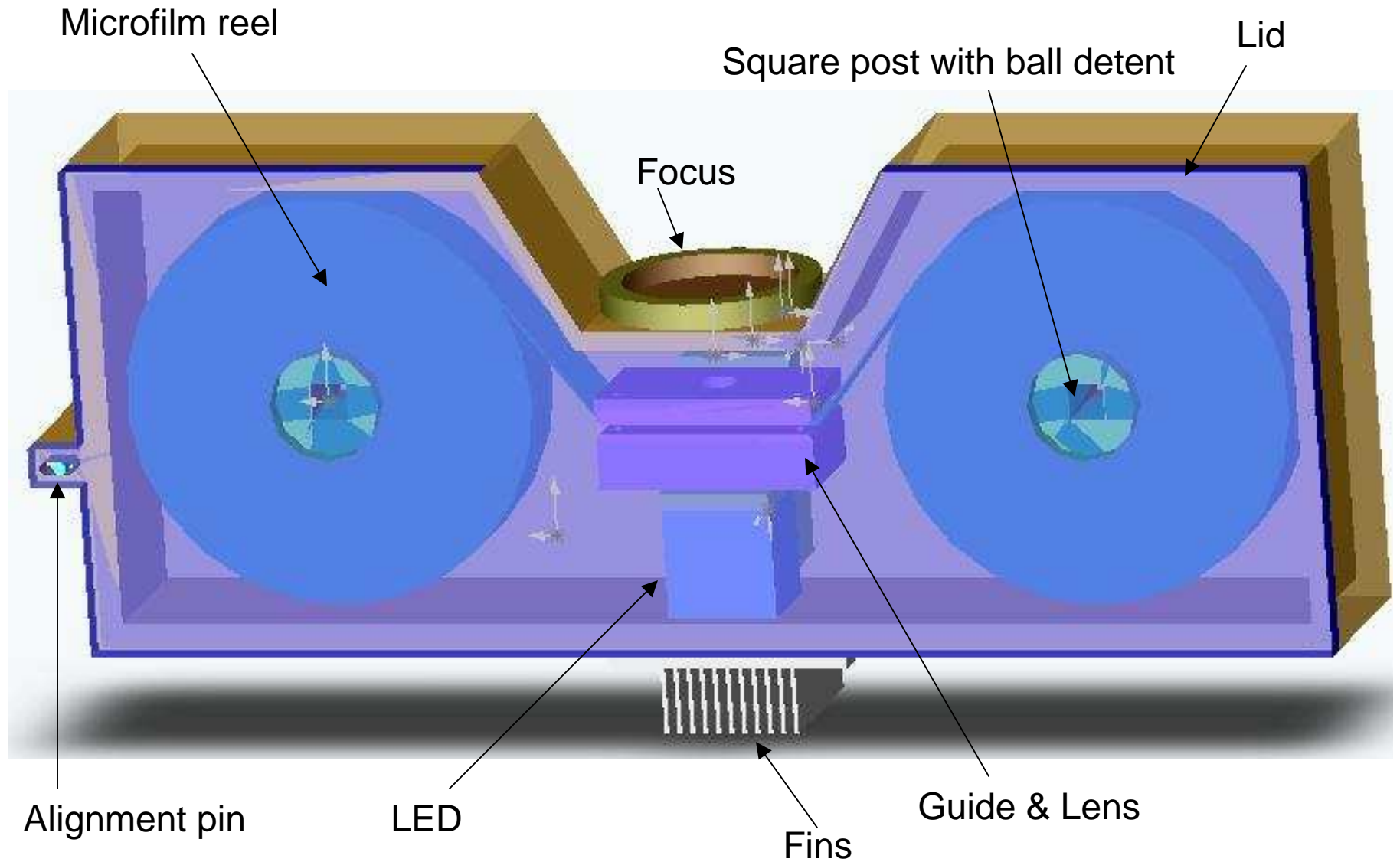

# Chassis Assembly

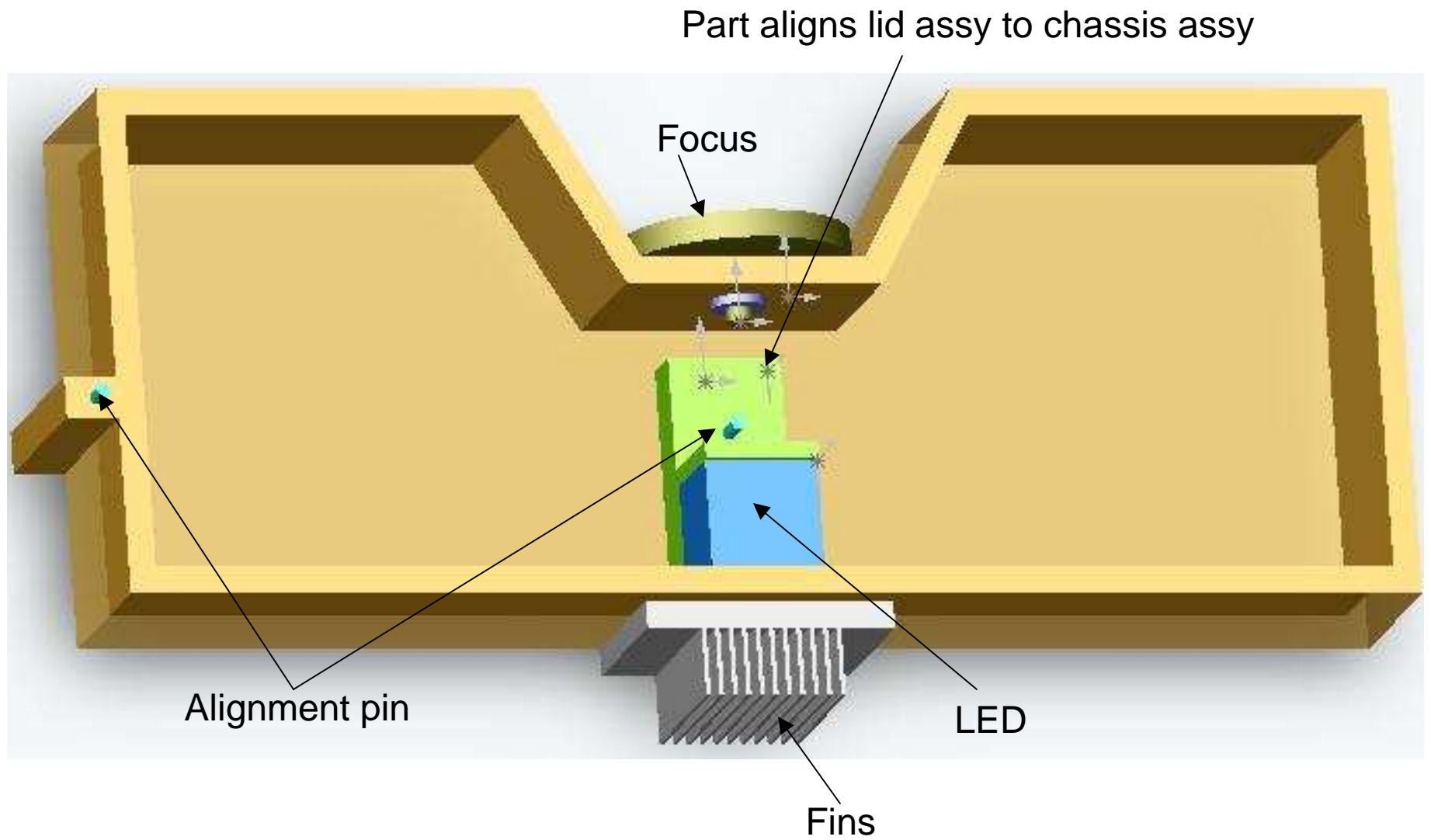

# Lid Assembly

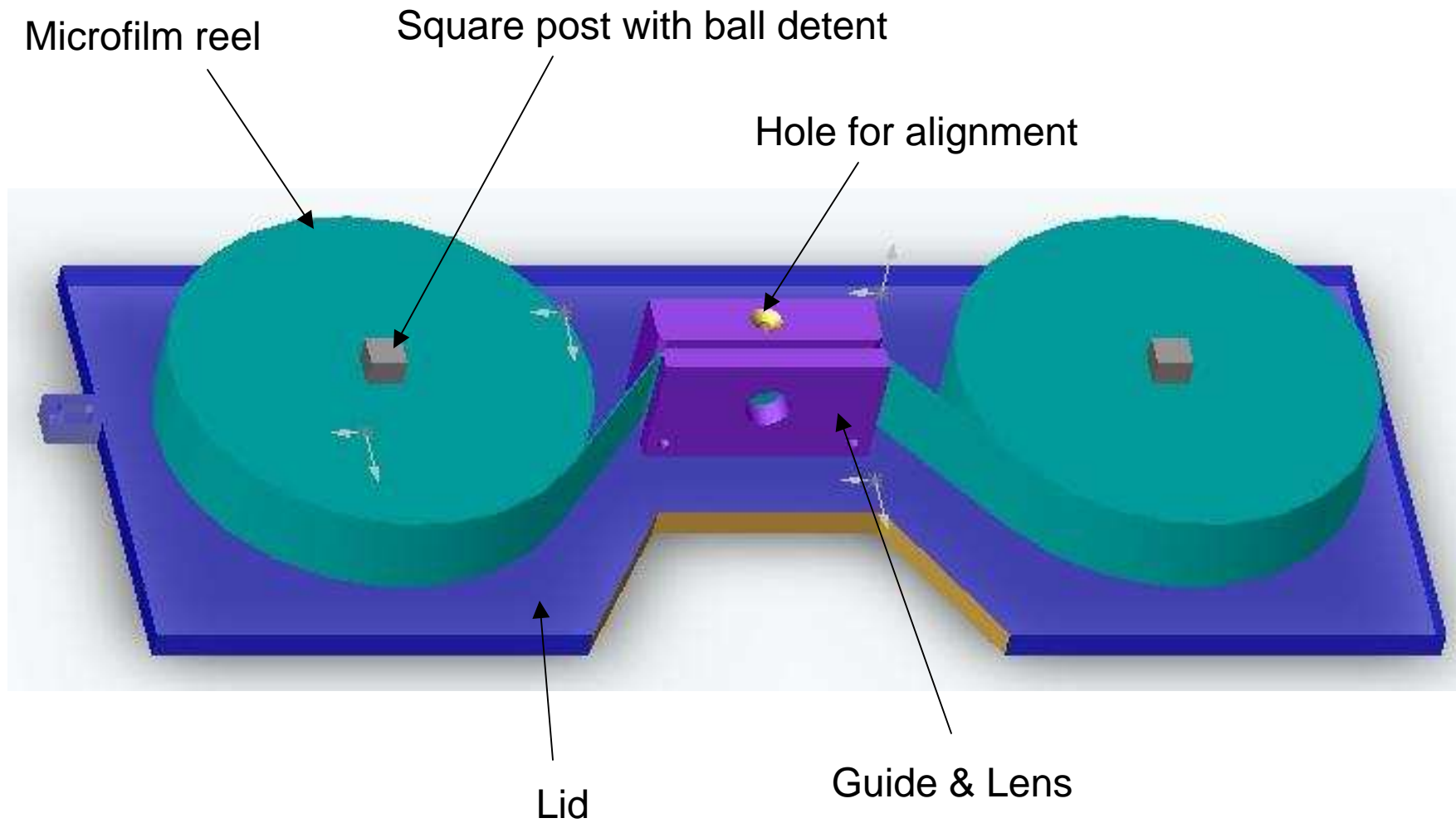

# Variation Sensitivity Analysis

Dots are parts, or features on parts, black lines are connections, and red lines dimensions critical to performance

## CURRENT DESIGN

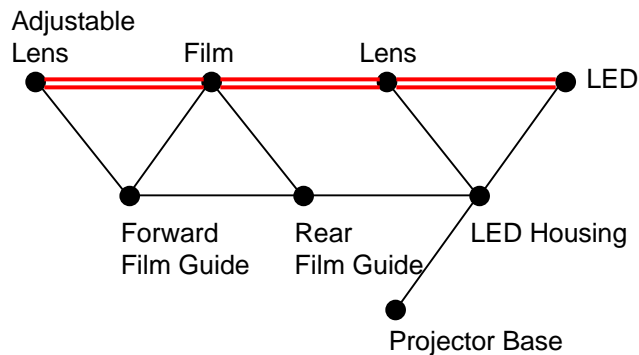

## PROPOSED DESIGN

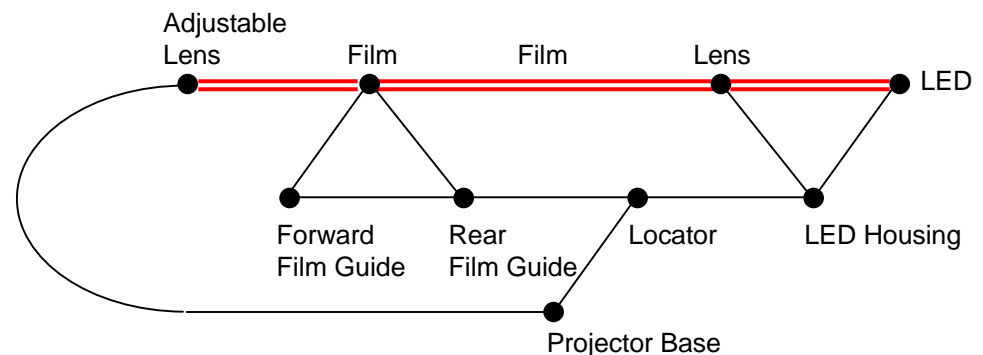

Current design is quite good. Proposed design seems worse until the fact the front lens is adjustable is taken into account.

Further analysis not possible without information on production tolerances.

# Manufacturing Setups

Presumed number of setups for gamma design and proposed design

## GAMMA DESIGN

PART	TIME	COST
CHASSIS		
Extrude / Cut		
Face / Drill		
Face		
Drill		
Drill		
Attach Halves		
Manufacture Base		
Drill		
Attach Film Guide		
Attach Drive Mechanism		
Attach to Chassis		
Attach Feet		
LED		
Attach to Chassis		
LID		
Manufacture		
Drill		
Attach Drive Mechanism		

## PROPOSED DESIGN

PART	TIME	COST
CHASSIS		
Cast		
Face / Drill		
Drill		
Drill		
Attach Heat Sink (Could Integrate)		
Attach Feet		
Attach LED Guide		
LED		
Attach to Guide		
LID		
Manufacture		
Drill		
Attach Drive Mechanism		
Attach Film Guide		

# Design decomposition maps functional requirements to design parameters

0	FR	Project printed material onto a screen	DP	Projector system	PV
1	FR	Provide energy	DP	Power source	PV
2	FR	Project image from microfilm onto screen	DP	Imaging system	PV
2.1	FR	Load microfilm into system	DP	Loading system	PV
2.1.1	FR	Accomodate Kodak desktop microfilm	DP	Kodak desktop microfilm interfaces	PV
2.1.2	FR	Change microfilm reels without tools	DP	Ball detents on microfilm holder	PV
2.1.3	FR	Accomodate TBD pages of microfilm tape	DP	Spool	PV
2.2	FR	Present microfilm to designated location	DP	Microfilm advancing system	PV
2.2.1	FR	Manually advance/rewind microfilm	DP	Crank crank adjustment	PV
2.2.2	FR	Adjust projected frame in image plane	DP	Crank fine adjustment	PV
2.2.3	FR	Ensure microfilm is not bent	DP	Microfilm guides	PV
2.3	FR	Shine light through designated location	DP	Optics system	PV
2.3.1	FR	Project TBD candles on axis	DP	Light source	PV
2.3.2	FR	Project TBD candles at 75% off axis	DP	Light reflector?	PV
2.3.3	FR	Focus projected image	DP	Distance between lenses?	PV
3	FR	Ensure exterior temperature of projector does not exceed TBD F	DP	Thermal design	PV
4	FR	Protect system against dirt and dust	DP	Sealed external body design	PV
5	FR	Enable projector to be carried	DP	Handle?	PV

